

# Technical Session RightNow Integration and Customization Techniques

Casey Bartz  
Development Services Manager  
RightNow Technologies



# Today's Mission

- Integration Overview
  - Integration Options
  - Best Practices for Development
- Conceptual Overview
  - Application Programming Interface (API) Overview
  - External Events & Email Events
  - Application Portal
  - Pass Through Authentication
  - Screen Pop
  - Custom Tables
- Customization Options
  - File Manager
  - Examples
- Integration Enhancements in RightNow 8



# Integration Overview



# Primary Methods of Integration

## *Primary Methods:*

- XML API
- External Events and Email Event Handlers
- Data Transfer Utilities
- ODBC
- Pass Through Authentication
- Application Portal



# Best Practices for Integration Projects

- Identify the business case first
  - Demonstrate the value to users and the organization
  - For example: If you require real-time look up of order information, you would determine the cost savings of presenting this information to your agents in a real-time fashion.
- Identify data transfers and custom data mappings
- Utilize standards based methods of data transfer
- Identify existing interfaces



# XML API

*The XML API is used to transfer information from an enterprise application to RightNow. For example when integrating an external customer database it would be necessary to use the contact create API.*

- Can be used via the web or email
- Most flexible method of integration
- Can be used in conjunction with external events



# Object Level XML API Overview

Each of the objects listed below are available through an API function.

- RightNow Service and Support
  - Create, Update, Destroy– Account, Answers, Hierarchical Menu, Organizations, Contacts, Incidents, Staff, Products, Categories, SLAs, Tasks
  - Get – Answers, Organizations, Contacts, Incidents
  - Move – Account, Hierarchical Menu
- RightNow Sales
  - Create, Update, Destroy and Get - Opportunities, Tasks
  - Update – Quotes
- RightNow Marketing
  - Execute – Campaign



# XML Search API & Query API

*Used to query the RightNow application to return specific data based on the view contained in RightNow.*

- Pass in a valid custom view ID
- Returns the information contained in the view in XML
- Can pass in values for run time selectable filters to greater enhance the return values
- Query API provides the ability to query the database through the API



# Mail To Contact Function

- Can be combined with the contact\_create and/or contact\_update functions for creating and/or updating a contact and sending them an email in the same XML post
- The schedule parameter allows you to schedule an event-triggered email to happen at a later date/time
- The parameters of this function include c\_id, mailing\_id, campaign\_id, node\_id, filter\_id, and scheduled



# Email Event and External Event Handlers

*External Events are used to push information from RightNow to another application. For example if you are integrating customer information you would use a customer External Event to push information out of RightNow.*

- Supports the same events as the XML application bridge
- Extremely flexible method of integration
- Customizable PHP pages to perform specific functions



# Pass Through Authentication

*Pass login information from your website to RightNow.*

- Seamless login from your website to RightNow
- Consistent customer information between applications
  - Ability to create or update a customer record
  - Customer registration integration
- Encryption options available
- Agent authentication also available through an Active Directory connector
  - Create, modify and enable/disable accounts
  - Eliminates redundant work



# Application Portal

## CUSTOM TABS

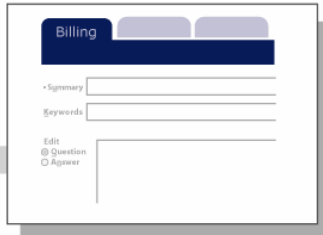

A screenshot of a custom tab interface for 'Billing'. The tab is highlighted in dark blue. Below the tab, there are three input fields: 'Summary', 'Keywords', and 'Edit'. The 'Edit' section contains two radio buttons: 'Question' and 'Answer'.

**ERP: Billing System  
& Account Information**



A screenshot of a custom tab interface for 'Order Tracking'. The tab is highlighted in dark blue. Below the tab, there are three input fields: 'Summary', 'Keywords', and 'Edit'. The 'Edit' section contains two radio buttons: 'Question' and 'Answer'.

**Order Creation,  
Tracking & Status**



A screenshot of a custom tab interface for 'Inventory'. The tab is highlighted in dark blue. Below the tab, there are three input fields: 'Summary', 'Keywords', and 'Edit'. The 'Edit' section contains two radio buttons: 'Question' and 'Answer'.

**Supply Chain/  
Inventory Management**

*Creates an Application Portal from RightNow.*

- Used to display web-based applications within the support console
- Can be used for order tracking applications or supply chain applications
- Loosely coupled integration methodology
- For Example: A tab could be created for real-time look up of order information. If the incident contains an order ID an agent could click on the custom tab and it would show the order status.



# Screen Pop Function

- RightNow allows you to open, or “pop,” the Support Console and Sales Console from a third party application
- An HTTP GET function is then used to form a request to the staff member’s localhost
- When opening a console, you can pass parameters to the RightNow browser to open a specified console view or open incident or opportunity information in the tab set



# Custom Table Overview

- Ability to create custom tables for custom information storage
- Utilized with the Application Portal functionality
- Can be compiled into Analytics and Views for custom information layout and reporting
- Examples include Order, RMA, Inventory and Warranty information



# Customization Options

- Customer PHP pages can be customized to facilitate integration into another application
- Completely integrate the look-and-feel of your website into a RightNow interface
- All end-user PHP files accessible through the RightNow application via the File Manager
- Examples:

- <http://leapfrog.com>
- <http://orbitz.com>
- <http://iomega.com>
- <http://logitech.com>

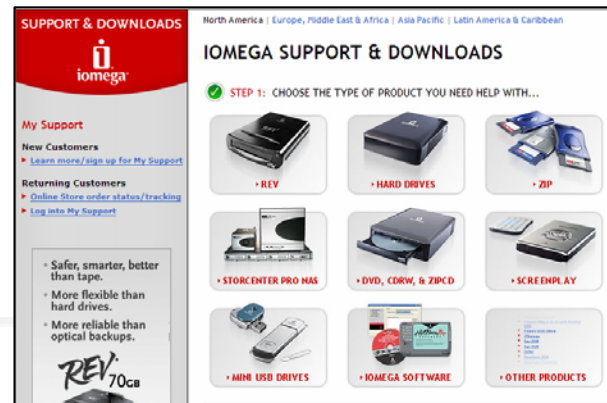
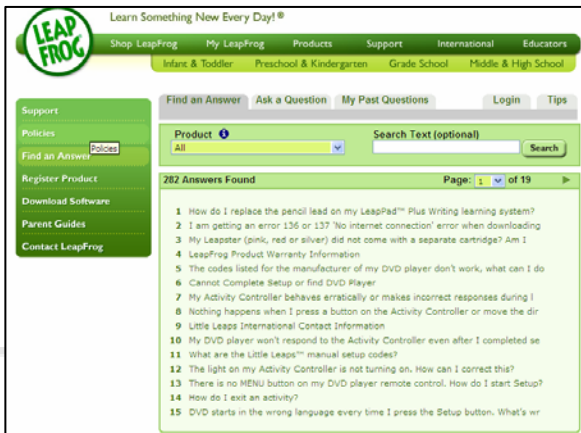
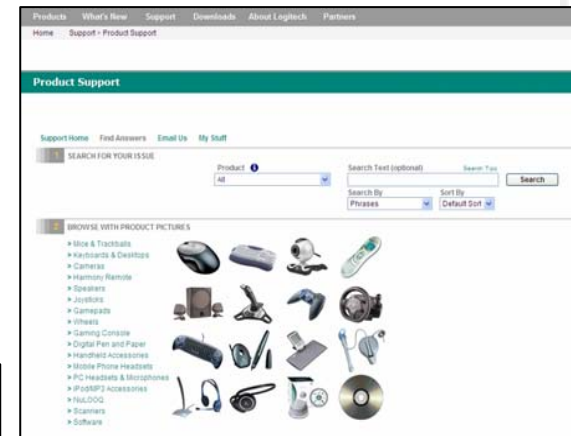
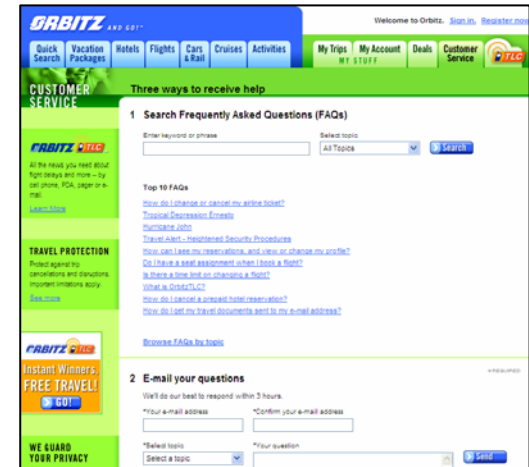

# RightNow 8 Logical Architecture

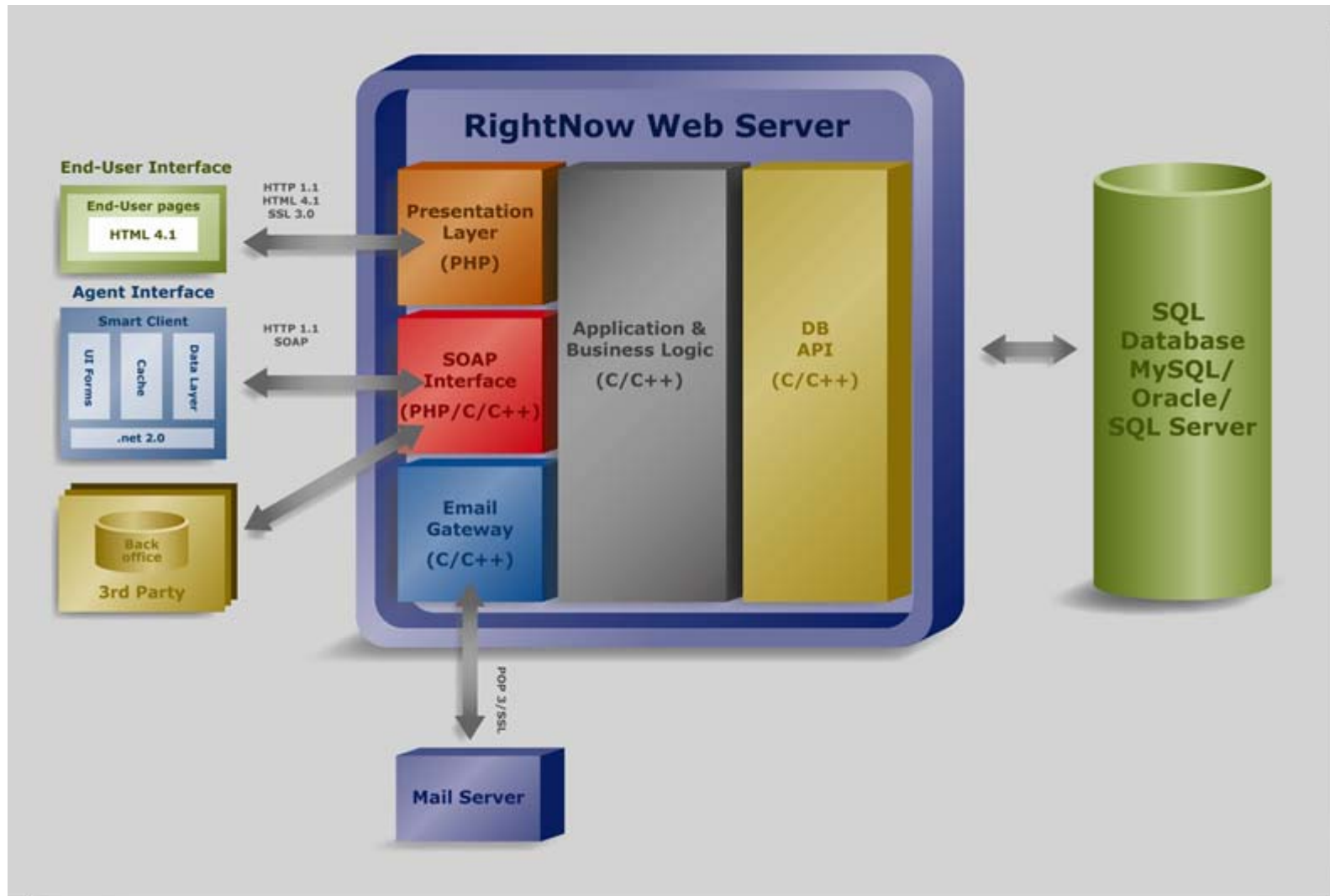

# What is SOAP?

SOAP (Simple Object Access Protocol)

is a way for a program running in one kind of operating system (such as Windows 2000) to communicate with a program in the same or another kind of an operating system (such as Linux) by using the World Wide Web's Hypertext Transfer Protocol (HTTP) and its Extensible Markup Language (XML) as the mechanisms for information exchange.

Since Web protocols are installed and available for use by all major operating system platforms, HTTP and XML provide an already at-hand solution to the problem of how programs running under different operating systems in a network can communicate with each other.

SOAP specifies exactly how to encode an HTTP header and an XML file so that a program in one computer can call a program in another computer and pass it information. It also specifies how the called program can return a response.



# SOAP Advantage

- Program calls are more likely to get through firewalls
  - Firewalls screen out requests other than those for known applications (through the designated port mechanism).
  - Since HTTP requests are usually allowed through firewalls, programs using SOAP to communicate can be sure that they can communicate with programs anywhere.
- Platform neutral data exchange
  - SOAP enables two programs to communicate independent of the O/S (Microsoft client & Linux Server)
- Program objects move from memory to serialized stings and back into memory without significant effort
- It is easier to write, manage and debug code in a SOAP, Smart Client and Web Service environment – than it is in an HTML/PHP environment



# SOAP in RightNow 8

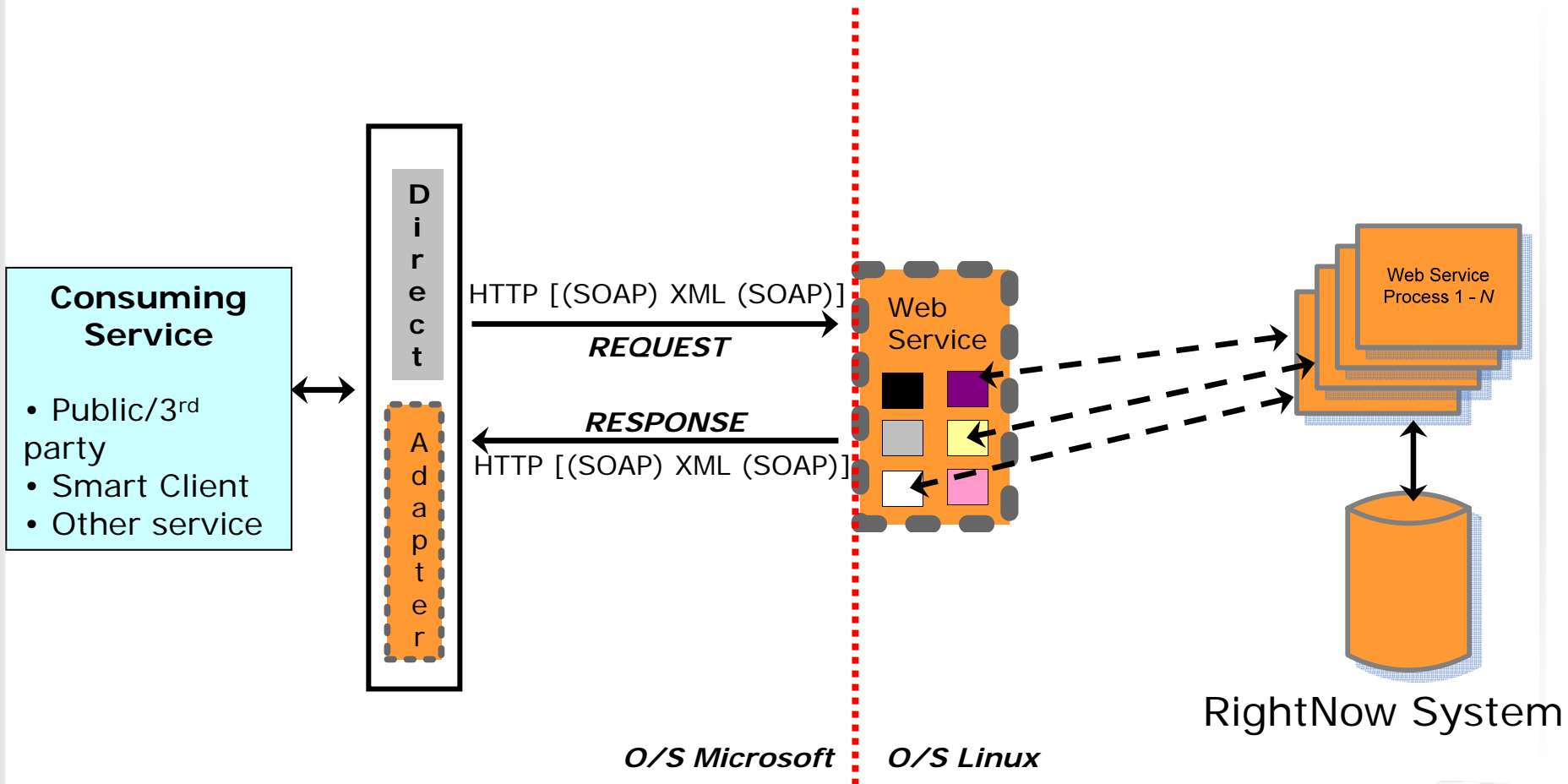



**CAST IRON**  
S Y S T E M S

INTEGRATE IN DAYS

---

# **RightNow Integration in days using an Integration Appliance**

---

Chandar Pattabhiram  
Senior Director, Product Marketing, Cast Iron Systems

# Topics



[www.castironsys.com](http://www.castironsys.com)

- Cast Iron Overview
- Live Demo
- Q&A

# Traditional Integration



(1) Program using complex integration tools

(2) Program using development tools

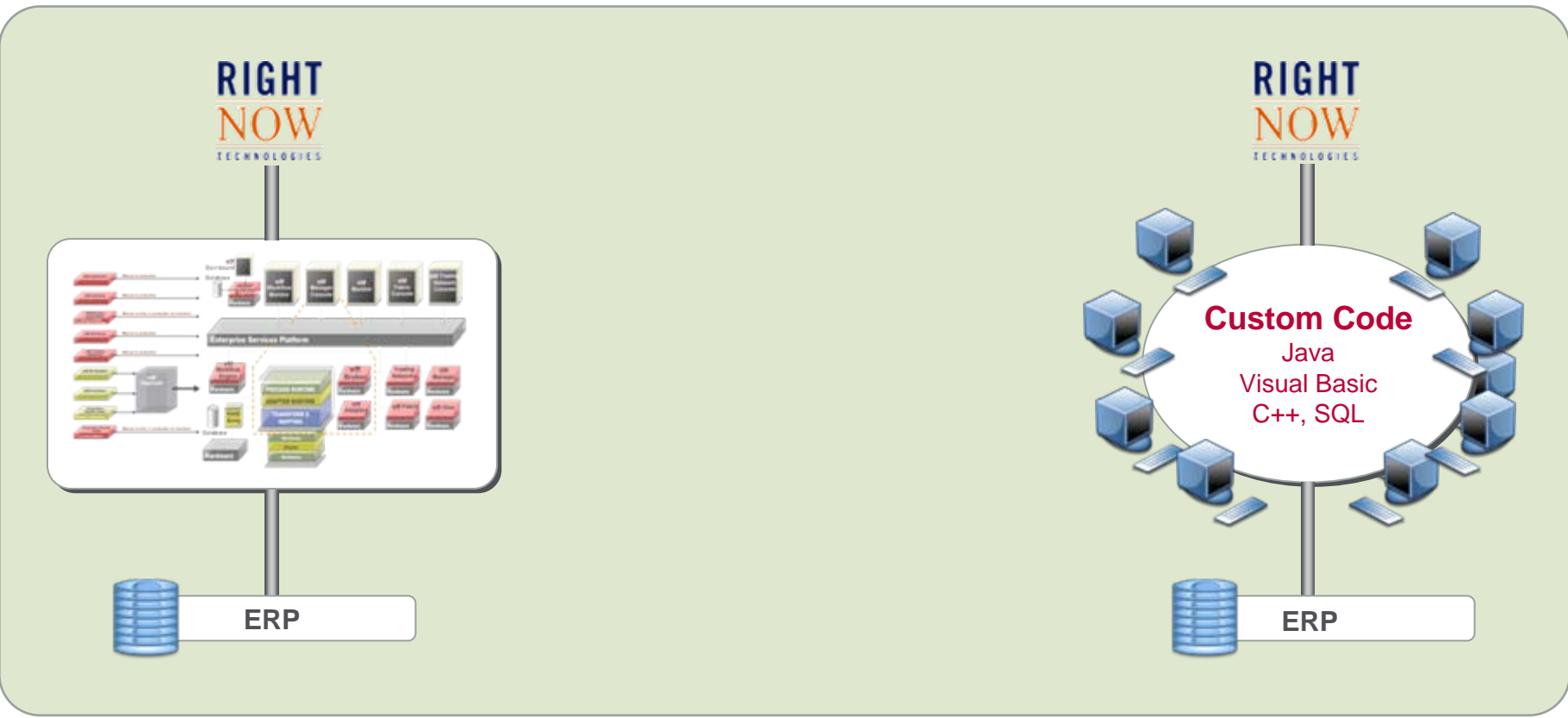

(1) Program using complex integration tools

(2) Program using development tools

RIGHT

RIGHT

## Complex Experience

- Install and maintain multiple components
- Write integration code
- Re-write integration code
- Multiple tools needed to track integration health

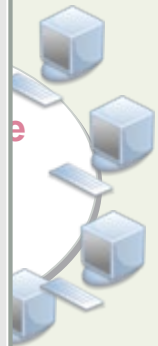

(1) Program using complex integration tools

(2) Program using development tools

RIGHT

RIGHT

## Simple Experience

- One device
- No coding
- No re-coding
- One console



# The RightNow Integration Appliance



www.castironsys.com



Cast Iron **Integration Appliance**

 **ERP**  
(Lawson, JD Edwards, Oracle, SAP, PeopleSoft)

 **Flat-files/Excel**  
(FTP, HTTP, E-mail)

 **All Major Databases**

 **All Major On-Demand Applications**

 **XML & Web Services**

 **Custom Applications**

1 Data Migration from ERP

2 Real-time Data synchronization with other systems







3 Data extraction to reporting systems

# Proven Results



www.castironsys.com

## Integrate in Days for 80% Less Cost

Company	Description	Project Duration (in Days)	Cost Savings
 <b>MOTOROLA</b>	Large electronic manufacturer	15	76%
	Leading security vendor	7	83%
	\$227M surgical device manufacturer	11	82%
	Conglomerate of mid-size manufacturers	15	81%
	\$770M mid-market ERP	5	86%
	Fastest growing wireless router manufacturer	7	85%

# RightNow Appliance Overview



www.castironsys.com

## RightNow integration made easy



### What The Integration Appliance Does

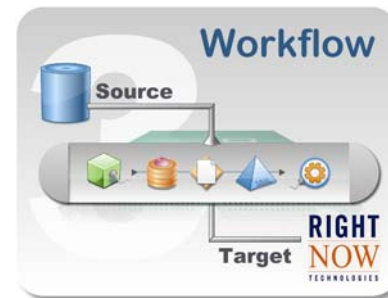
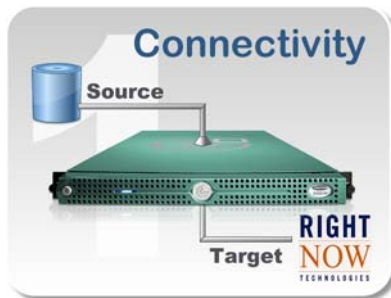

# Live Demo



www.castironsys.com

What



How

1 Plug in



2 Configure

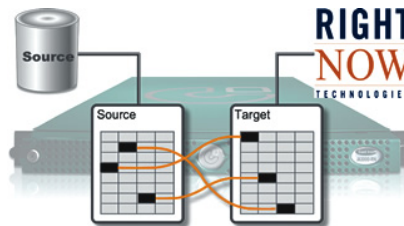

3 Go



Questions?



# Resources

- White Paper: “Your Guide to Integrating RightNow Service with Other Enterprise Applications”
- Professional Services Booth
- [Rightnow.custhelp.com](http://Rightnow.custhelp.com)
- Your account manager

